

# User Manual

# 3DM883

## Digital 3-Phase Microstep Drive

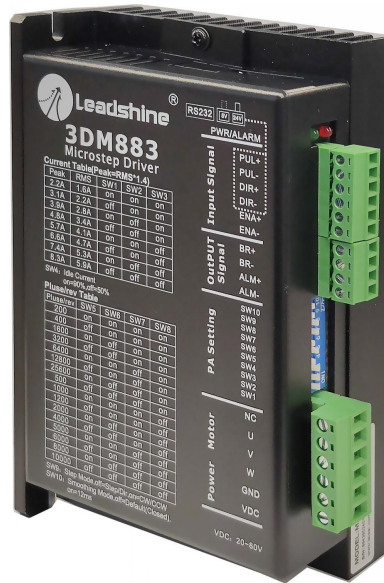

**Revision 1.0**

**©2020 Leadshine Technology Co., Ltd.**

*Address:* 15-20/F, Block B, Nanshan I Valley, No.3185, Shahe West Road, Nanshan District,  
Shenzhen, Guangdong, 518055, China

*Tel:* (86)755-26409254

*Fax:* (86)755-26402718

*Web:* [www.leadshine.com](http://www.leadshine.com)

*Sales:* [sales@leadshine.com](mailto:sales@leadshine.com)

*Support:* [tech@leadshine.com](mailto:tech@leadshine.com)

## Important Notice

Read this manual carefully before any assembling and using. Incorrect handling of products in this manual can result in injury and damage to persons and machinery. Strictly adhere to the technical information regarding installation requirements.

This manual is not for use or disclosure outside of Leadshine except under permission. All rights are reserved. No part of this manual shall be reproduced, stored in retrieval form, or transmitted by any means, electronic, mechanical, photocopying, recording, or otherwise without approval from Leadshine. While every precaution has been taken in the preparation of the book, Leadshine assumes no responsibility for errors or omissions. Neither is any liability assumed for damages resulting from the use of the information contained herein.

This document is proprietary information of Leadshine that is furnished for customer use ONLY. Information in this document is subject to change without notice and does not represent a commitment on the part of Leadshine. Therefore, information contained in this manual may be updated from time-to-time due to product improvements, etc., and may not conform in every respect to former issues.

## Record of Revisions

<b>Revision</b>	<b>Date</b>	<b>Description of Release</b>
<i>1.0</i>	<i>Sept, 2020</i>	<i>Initial Version.</i>

## Table of Contents

<b>1. Introduction.....</b>	<b>1</b>
1.1 Features.....	1
1.2 Applications.....	1
<b>2.Specifications.....</b>	<b>1</b>
2.1 Electrical Specifications.....	1
2.2 Environment.....	2
2.3 Mechanical Specifications.....	2
2.4 Elimination of Heat.....	2
<b>3. Connection Pin Assignments and LED Indication.....</b>	<b>3</b>
3.1 P1 - Control Connector.....	3
3.2 P2 - Fault and Brake Output Connector.....	3
3.3 P3 - Motor and Power Supply Connector.....	4
3.4 P4 - Tuning Port.....	4
3.5 Status LED (Protection Functions).....	4
<b>4. Control Signal and Fault Output Wiring.....</b>	<b>5</b>
4.1 Control Signal Connection.....	5
4.2 Fault and Brake Outputs Connection.....	5
4.3 Sequence Chart of Control Signals.....	6
4.4 Typical Connection.....	7
<b>5. DIP Switch Configurations.....</b>	<b>7</b>
5.1 Microstep Resolution Configurations.....	8
5.2 Output Current Configurations.....	8
5.2.1 Dynamic Current Configurations.....	8
5.2.2 Idle Current Configuration.....	9
5.3 Control Mode Configurations.....	9
5.4 Smoothing Time Configuration.....	9
5.5 Automatic Motor Matching & Self Configuration.....	9
<b>6. Power Supply Selection.....</b>	<b>9</b>
6.1 Regulated or Unregulated Power Supply.....	9
6.2 Power Supply Sharing.....	10
6.3 Selecting Supply Voltage.....	10
<b>7. Motor Selection.....</b>	<b>10</b>
<b>8. Troubleshooting.....</b>	<b>11</b>
<b>9. Warranty.....</b>	<b>12</b>

## 1. Introduction

The 3DM883 is Leadshine newest digital stepper drive based on an advanced control algorithm. It brings a unique level of system smoothness, providing optimum torque and nulls mid-range instability. Motor self-test and parameter auto-setup technology offers optimum responses with different motors and easy-to-use. The driven motors can run with much smaller noise, lower heating, smoother movement than most of the drives in the markets. Its unique features make the 3DM883 an ideal solution for applications that require low-speed smoothness.

### 1.1 Features

- Step & direction (PUL/DIR) or CW/CCW (double pulse) control
- Power supply voltage 20-74 VDC
- 400KHz max pulse input frequency in dutycycle 50%
- 16 microstep resolutions of 200-25,600 via DIP switches, or 200-51,200 via software (increase by 100)
- 8 output current settings of 2.2 -8.3A via DIP Switches, or 0.5-8.3A via software (increase by 0.1)
- Configurable control command smoothing for reducing motor vibration
- Idle current reduction to 50% or 90% selection via SW4
- Anti-Resonance for optimal torque, extra smooth motion, low motor heating and noise
- Soft-start with no “jump” when powered on
- Fault and Brake outputs
- Over-voltage, over-current protections
- CE certified and RoHS compliant

### 1.2 Applications

Suitable for a wide range of 3-phase stepper motors, from NEMA frame size 23 to 34. It can be used in various kinds of machines, such as laser cutters, laser markers, high precision X-Y tables, labeling machines, and so on. Its unique features make the 3DM883 an ideal solution for applications that require both low-speed smoothness and high speed performances.

## 2. Specifications

### 2.1 Electrical Specifications

Parameters	Min	Typical	Max	Unit
Output Current	0.5	-	8.3 (5.9 RMS)	A
Supply Voltage	20	24 - 60	74	VDC
Logic signal current	7	10	16	mA
Pulse input frequency	0	-	400	kHz
Minimal pulse width	1.2	-	-	μs
Minimal direction setup	5	-	-	μs
Isolation resistance	500	-	-	MΩ

## 2.2 Environment

Cooling	Natural Cooling or Forced cooling	
Operating Environment	Environment	Avoid dust, oil fog and corrosive gases
	Ambient Temperature	0 — 65°C (32 - 149°F)
	Humidity	40 — 90%RH
	Operating Temperature	0 — 50°C (32 - 122°F)
	Vibration	10-50Hz / 0.15mm
Storage Temperature	-20°C — 65°C (-4°F - 149°F)	
Weight	Approx. 500g (17.6 oz)	

## 2.3 Mechanical Specifications

(unit: mm [inch], 1 inch = 25.4 mm)

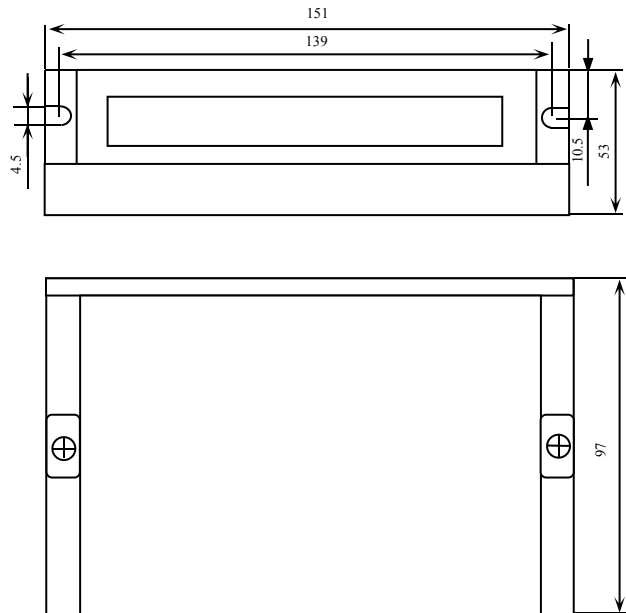

**Figure 1** Mechanical specifications

\* Side mounting recommended for better heat dissipation

## 2.4 Elimination of Heat

- Drive's reliable working temperature should be <70°C (158°F), and motor working temperature should be <80°C (176°F);
- It is recommended to use automatic idle-current mode, namely current automatically reduce to 50% when motor stops, so as to reduce Drive heating and motor heating;
- It is recommended to mount the Drive vertically to maximize heat sink area. Use forced cooling method to cool the system if necessary.

### 3. Connection Pin Assignments and LED Indication

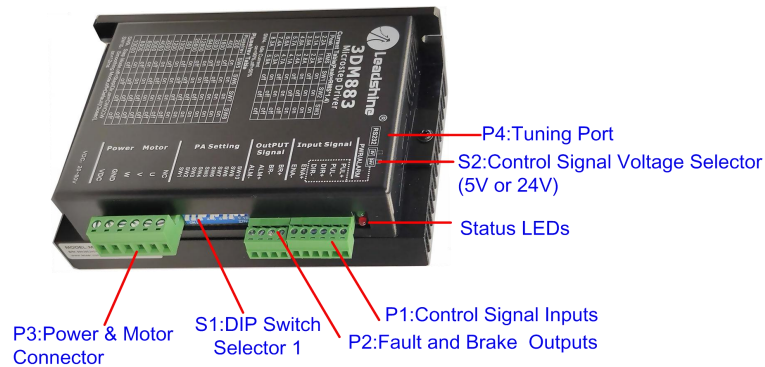

**Figure 2** Connectors, DIP switches, and LED locations

The 3DM883 has 4 connectors P1, P2, P3 and P4, 2 DIP switches S1 and S2. P1 is for control signal connections, P2 is for fault and brake outputs, P3 is for power and motor connection, P4 is for fine tuning.

#### 3.1 P1 - Control Connector

PIN	Details
PUL+ (CW+)	<u>Pulse and Direction Connection:</u> (1) Optically isolated, high level 4.5-5V or 24V, low voltage 0-0.5V (2) Maximum 400 KHz input frequency (3) The width of PUL signal is at least 1.2 $\mu$ s, duty cycle is recommended 50% (4) Single pulse (step & direction) or double pulse (CW/CCW) is set by DIP Switch SW9 (5) DIR signal requires advance PUL signal minimum 5 $\mu$ s in single pulse mode (6) The factory setting of control signal voltage is 24V, <b>must need</b> to set S2 (figure 2) if it is 5V
PUL- (CW-)	
DIR+ (CCW+)	
DIR- (CCW-)	
ENA+	
ENA-	<u>Enable Connection:</u> (default no connection) (1) Optically isolated, differential. (2) Disable the drive by 4.5- 24V input connection; enable the drive by 0-0.5V connection (3) ENA signal requires advance DIR signal minimum 5 $\mu$ s in single pulse mode (4) Enable time to be at least 200ms

#### Notes:

- (1) Shield cables are required for P1;
- (2) Don't tie P1/P2 cables and P3 cables together.

#### 3.2 P2 - Fault and Brake Output Connector

Pin	Details
BRK+	(1) Maximum 30V/100mA output (4) Brake connection refer to <a href="#">chapter 4.2</a>
BRK-	

<b>ALM+</b>	(1) Maximum 30V/100mA output (2) Sinking or sourcing
<b>ALM-</b>	(3) The resistance between ALM+ and ALM- is low impedance as default, and will change to high when the drive goes into error protection. (4) Fault connection refer to <a href="#">chapter 4.2</a>

### 3.3 P3 - Motor and Power Supply Connector

Pin Name	Description
NC	Reserved, no connection
U	Motor phase U
V	Motor phase V
W	Motor phase W
GND	Connect to power supply ground connection
+Vdc	Connect to power supply positive connection. 20-74VDC, considering voltage fluctuation and EMF voltage.

### 3.4 P4 - Tuning Port

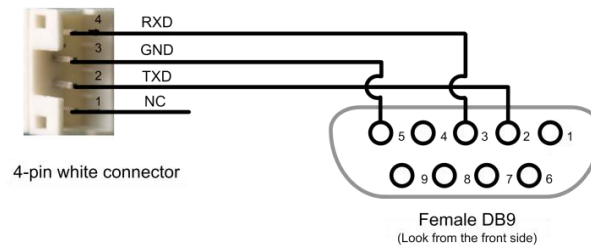

3DM883 has a tuning port with RS232 to modify the drive parameters, it's only for tuning, not for equipment control because neither precision nor stability is sufficient. The interface definition is as follows:



**Figure 3** Tuning Port

### 3.5 Status LED (Protection Functions)

There are two LED lights for 3DM883. The GREEN one is the power indicator which should be always on in normal circumstance. The RED one is a drive status indication light, which will be OFF while working normally but ON and flash 1 or 2 times in a 3-second period in the case of enabled over-current or over-voltage protection.

Priority	Time(s) of Blink	Sequence wave of red LED	Description
1 <sup>st</sup>	Always on		The drive was short-circuited or burned out.
1 <sup>st</sup>	1		Over-current protection activated when peak current exceeds the limit.

2 <sup>nd</sup>	2		Over-voltage protection activated when drive working voltage is greater than 160VDC
-----------------	---	---	---

## 4. Control Signal and Fault Output Wiring

### 4.1 Control Signal Connection

The 3DM883 can accept differential and single-ended control signal inputs (open-collector and PNP output). A 3DM883 has 3 optically isolated control inputs, PUL, DIR, and ENA. Refer to the following two figures for connections of open-collector and PNP signals.

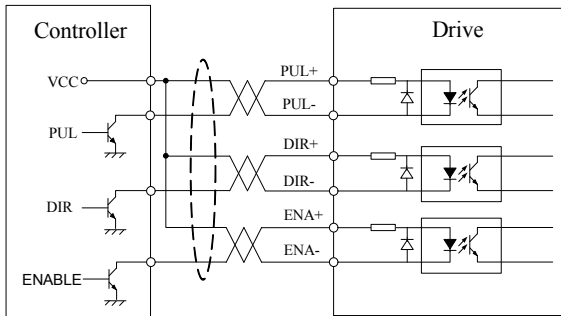

**Figure 4:** Connections to open-collector signal (common-anode)

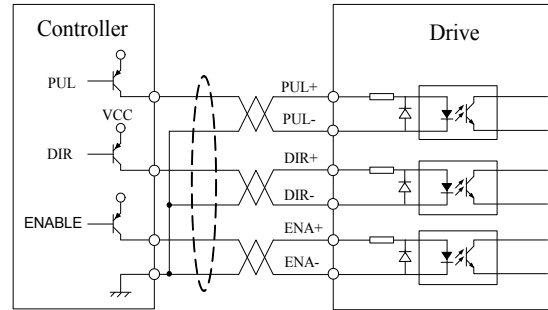

**Figure 5:** Connections to PNP signal (common-cathode)

#### Notes:

- (1) ENA signal is no-connected as default;
- (2) Control signal amplitude is 24 V as default. If it is 12 V, please set the S2 (Figure 2) selector switch to 5 V first, then connect 1K $\Omega$  resistor; If it is 5V, please set the S2 to 5V.

### 4.2 Fault and Brake Outputs Connection

- Fault Output

When over voltage or over current protection happens, 3DM883 red status LED light will blink and the impedance state between ALM+ and ALM- will change (from low to high or high to low depending on configuration) and can thus be detected. Fault output connection is optional, and it can be connected either in sinking or sourcing.

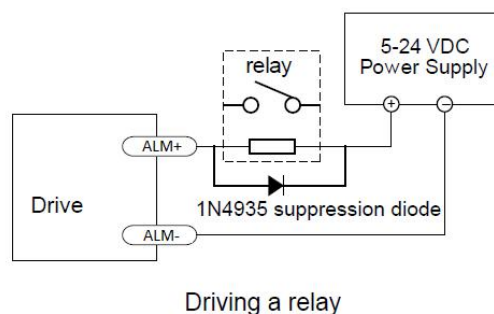



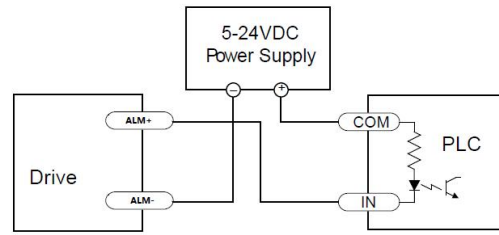

Connecting a sinking output to a PLC's input

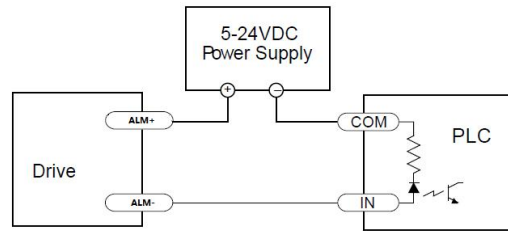

Connecting a sourcing output to a PLC's input

**Figure 6** Fault output connections

- Brake Control

This signal can be used for automatic brake control while system power failure.

When use a 24V electromagnetic relay, it is recommended to connect a diode (such as IN4007) in parallel, the polarity should not be reversed. The specific connection is as follows figure7A . When use a solid-state relay (SSR), its advantages are fast response, no need to add diodes, no noise; specification such as “Non-contact, DC control DC, current limit protection 0.6-10A”.The specific connection is as follows figure7B

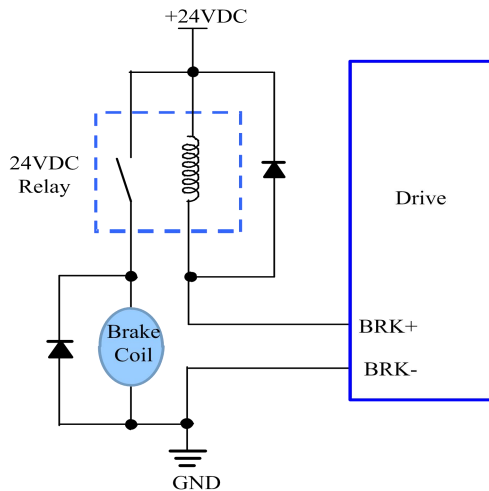
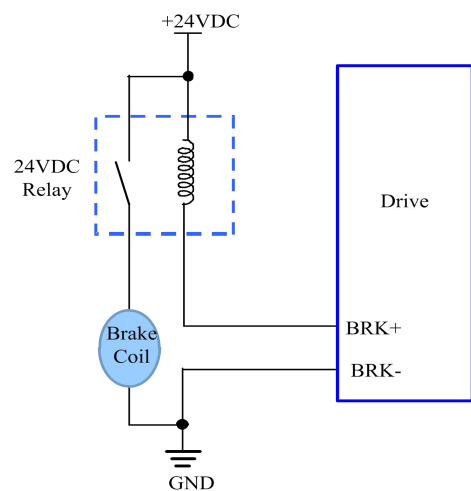
**Figure 7A** Brake output connections

**Figure 7B** Brake output connections

### 4.3 Sequence Chart of Control Signals

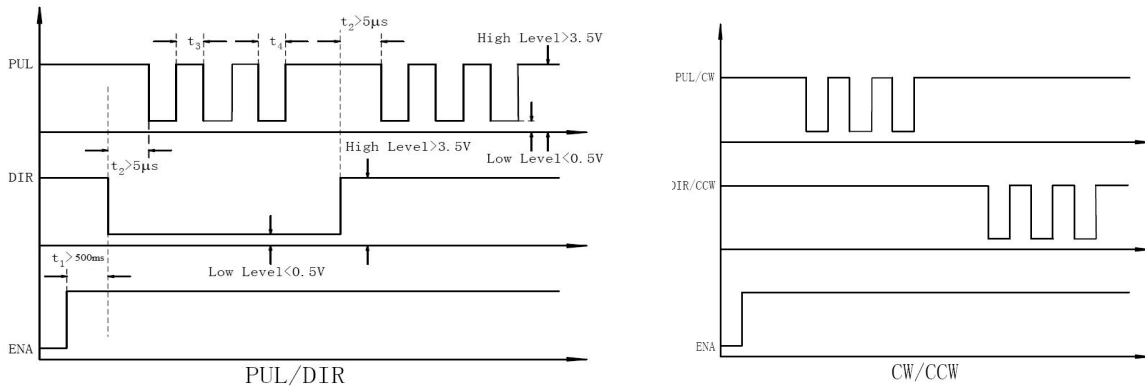
In order to avoid some fault operations and deviations, PUL, DIR and ENA should abide by some rules, shown as following diagram:



**Figure 8** Sequence chart of control signals

**Remark:**

- (1) t1: ENA must be ahead of DIR by at least 500ms. Usually, ENA+ and ENA- are NC (no connected).
- (2) t2: DIR must be ahead of PUL effective edge by 5µs to ensure correct direction.
- (3) t3: Pulse width not less than 1µs, these widths are based on a 50% duty cycle. If it is greater or less than 50%, the width time is required to be wider.

**4.4 Typical Connection**

- In order to improve anti-interference performance of the Drive, it is recommended to use twisted pair shield cable.
- To prevent noise incurred in PUL/DIR signal, pulse/direction signal wires and motor wires should not be tied up together. It is better to separate them by at least 10 cm, otherwise the disturbing signals generated by motor will easily disturb pulse direction signals, causing motor position error, system instability and other failures.
- If a power supply serves several Drives, separately connecting the Drives is recommended instead of daisy-chaining.
- It is prohibited to pull and plug connector P3 while the drive is powered ON, because there is high current flowing through motor coils (even when motor is at standstill). Pulling or plugging connector P3 with power on will cause extremely high back-EMF voltage surge, which may damage the Drive.
- It is strictly prohibited to add tin to the wire head to access the terminal, otherwise the contact resistance may become large and overheating damage to the terminal.
- The wire head should not be exposed outside the terminal to prevent accidental short circuit and damage to the drive.

**5. DIP Switch Configurations**

The 3DM883 has one 10-bit DIP switch and one 1-bit selector. The first 10-bit is used to configure settings of micro step resolution, output current, motor standstill current, pulse type and smoothing time as shown below.

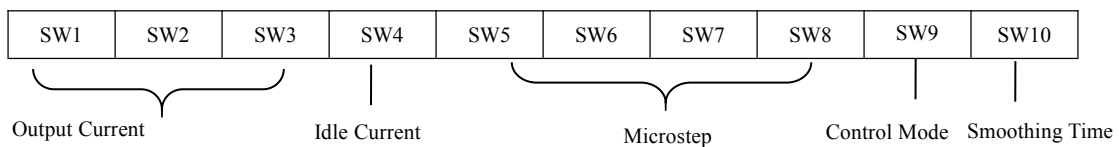

The second 1-bit selector is located on the top (S2 in figure 2), used to configure the voltage of control signals. For the safety of optically coupled, the factory setting is 24V, which no need to connect 2K resistors like the old drives, making it easier to use. When the voltage of the control signal is 5V, the S2 must be set to 5V, otherwise, [the motor won't work](#).

## 5.1 Microstep Resolution Configurations

Microstep resolution is set by SW5, 6, 7, 8 of the DIP switches as shown in the following table, **default** means can be set by Leadshine ProTuner

Microstep	Steps/rev.(for 1.8°motor)	SW5	SW6	SW7	SW8
1	200(default)	ON	ON	ON	ON
2	400	OFF	ON	ON	ON
8	1600	ON	OFF	ON	ON
16	3200	OFF	OFF	ON	ON
32	6400	ON	ON	OFF	ON
64	12800	OFF	ON	OFF	ON
128	25600	ON	OFF	OFF	ON
2.5	500	OFF	OFF	OFF	ON
5	1000	ON	ON	ON	OFF
6	1200	OFF	ON	ON	OFF
10	2000	ON	OFF	ON	OFF
20	4000	OFF	OFF	ON	OFF
25	5000	ON	ON	OFF	OFF
30	6000	OFF	ON	OFF	OFF
40	8000	ON	OFF	OFF	OFF
50	10000	OFF	OFF	OFF	OFF

## 5.2 Output Current Configurations

For a given motor, higher drive current will make the motor to output more torque, but at the same time causes more heating in the motor and drive. Therefore, output current is generally set to be such that the motor will not overheat for long time operation. Since parallel and serial connections of motor coils will significantly change resulting inductance and resistance, it is therefore important to set drive output current depending on motor phase current, motor leads and connection methods. Phase current rating supplied by motor manufacturer is important in selecting drive current, however the selection also depends on leads and connections.

The first three bits (SW1, 2, 3) of the DIP switch are used to set the dynamic current. Select a setting closest to your motor's required current.

### 5.2.1 Dynamic Current Configurations

Peak Current	RMS Current	SW1	SW2	SW3
2.2A(default)	1.6A	ON	ON	ON
3.1A	2.2A	OFF	ON	ON
3.9A	2.8A	ON	OFF	ON
4.8A	3.4A	OFF	OFF	ON
5.7A	4.1A	ON	ON	OFF
6.6A	4.7A	OFF	ON	OFF

7.4A	5.3A	ON	OFF	OFF
8.3A	5.9A	OFF	OFF	OFF

**Notes:** Due to motor inductance, the actual current in the coil may be smaller than the dynamic current setting, particularly under high speed condition. **Default** means can be set by Leadshine ProTuner

### 5.2.2 Idle Current Configuration

SW4 is used to set motor idle current percentage. At OFF position it means the standstill current is set to be 50% of the selected output current. At ON position it means standstill current is set to be 90%.

The current automatically reduced to 50% of the selected dynamic current 0.4 second after the last pulse.

### 5.3 Control Mode Configurations

DIP switch SW9 is used to configure the control mode. Factory setting is single pulse (step & direction, or pulse & direction) control. Setting to ON to change the control model to double pulse (CW/CCW) control type.

### 5.4 Smoothing Time Configuration

3DM883 has an advanced feature called control command smoothing to make the input pulse from pulse generator (controller, PLC, etc.) S-curve acceleration, to improve motion smoothness and high-speed start frequency in many circumstances. This is achieved through adding filtering time which is configured SW10. Setting to ON to activate the feature with 12ms acceleration time.

### 5.5 Automatic Motor Matching & Self Configuration

When powered on a 3DM883 will automatically configure itself with the best settings to match the driven stepper motor for optimal performance. No action is needed.

## 6. Power Supply Selection

The 3DM883 can power small and medium size 3-phase stepper motors (frame size from NEMA23 to 34) from Leadshine or other motor manufacturers. To get good system performance, it is important to select proper supply voltage and output current. Generally speaking, supply voltage determines the high speed performance of the motor, while output current determines the output torque of the driven motor (particularly at lower speed). Higher supply voltage will allow higher motor speed to be achieved, at the price of more noise and heating. If the motion speed requirement is low, it's better to use lower supply voltage to decrease noise, heating and improve reliability.

### 6.1 Regulated or Unregulated Power Supply

Both regulated and unregulated power supplies can be used to supply the drive. However, unregulated power supplies are preferred due to their ability to withstand current surge and fast response for current change. If you prefer to a regulated power supply, it is suggested to choose such a power supply specially designed for stepper/servo controls such as Leadshine LSP series . Or, in the case when only normal switching power supplies are available, it is important to use "OVERSIZE" high current output rating power supplies (for example, using a 4A power supply for 3A stepper motor) to avoid problems such as current clamp. On the other hand, if unregulated supply is used, one may use a power supply of lower current rating than that of motor (typically 50%-70% of motor current). The reason is that the drive draws current from the power supply capacitor of the unregulated supply

only during the ON duration of the PWM cycle, but not during the OFF duration. Therefore, the average current withdrawn from power supply is considerably less than motor current. For example, two 3A motors can be well supplied by one power supply of 4A rating.

## 6.2 Power Supply Sharing

Multiple 3DM883 drives can share one power supply to save space and reduce cost, if that power supply has enough power capacity. To avoid cross interference, connect each stepper drive directly to the shared power supply separately. To avoid cross interference, DO NOT daisy-chain connect the power supply input pins of the Drivers. Instead connect them to power supply separately.

## 6.3 Selecting Supply Voltage

The 3DM883 is designed to operate under 74VDC voltage input. When selecting a power supply, besides voltage from the power supply power line voltage fluctuation and back EMF voltage generated during motor deceleration needs also to be taken into account. Ideally it is suggested to use a power supply with the output of 20-48VDC, leaving room for power line voltage fluctuation and back-EMF.

Higher supply voltage can increase motor torque at higher speeds, thus helpful for avoiding losing steps. However, higher voltage may cause bigger motor vibration at lower speed, and it may also cause over-voltage protection or even drive damage. Therefore, it is suggested to choose only sufficiently high supply voltage for intended applications.

Model	Output Voltage (VDC)	Continuous Current(A)	Peak Current(A)	Input Voltage	Power (W)	Dimensions (mm)	Weight (Kg)
LSP-260-24	24	10.8	19.4	220VAC $\pm$ 10% or 110 VAC $\pm$ 10%	260	199*110*50	0.8
LSP-360-24	24	15	27		360	199*110*50	0.8
LSP-360-36	36	10	18		360	215*115*30	0.7
LSP-360-48	48	7.5	13.5		360	215*115*30	0.7
LSP-400-60	60	6.7	12		400	215*115*30	0.7

## 7. Motor Selection

The 3DM883 can be used to drive 3- or 6-wire three-phase hybrid stepper motors with a step angle of 1.2 degrees. The choice of motor is mainly determined by the motor torque and current rating. The torque size is mainly determined by the size of the motor. The larger the size of the motor, the higher the torque of the motor; while the current size is mainly related to the inductance, the motor with small inductance has good performance in high speed performance, but the current is higher.

Model	Length (mm)	Holding Torque(N.m)	Rate Current (A)	Resistance/Phase( $\Omega$ )	Inductance/Phase(mH)	Inertia (Kg.cm <sup>2</sup> )
573S09	50	0.9	3.5	0.77	1.8	1.00
573S15	76	1.3	5.8	0.86	2.0	1.40
863S22	71	2.3	5	0.9	2.8	2.50
863S42	103	4.3	5	1.35	4.5	2.70

## 8. Troubleshooting

In the event that your drive doesn't operate properly, the first step is to identify whether the problem is electrical or mechanical in nature. The next step is to isolate the system component that is causing the problem. As part of this process you may have to disconnect the individual components that make up your system and verify that they operate independently. It is important to document each step in the troubleshooting process. You may need this documentation to refer back to at a later date, and these details will greatly assist our Technical Support staff in determining the problem should you need assistance.

Many of the problems that affect motion control systems can be traced to electrical noise, controller software errors, or mistake in wiring.

### Problem Symptoms and Possible Causes

Trouble	Solution Measures
<b>Motor is not rotating</b>	No power, to start power supply
	Pulse/revolution setting is wrong
	DIP switch current setting is wrong
	Fault condition exists or the drive is disabled
<b>Motor rotates in the wrong direction</b>	Motor phases may be connected in reverse
	Pulse mode may be wrong
<b>Red light blinking</b>	Red light blinks 1 time or always on, try not to connect the motor and restart the power supply
	Red light blinks 2 times, check the power voltage and restart the power supply
<b>Erratic motor motion</b>	Current setting is too small, losing steps
	Wrong motor connection or has broken circuit in motor coil.
	The current of the control signals is not in the range of 7-15mA
	Control signals don't meet the requirements of <a href="#">chapter 4.3</a> , check the waveform of the control signals
<b>Motor stalls or loss steps</b>	Output current of the drive is too small or motor torque is not enough
	Acceleration is set too high
	Power supply voltage too low
	Modify the activated edge value in the PC software or the control signal is interfered with.
<b>Excessive motor and drive</b>	Inadequate heat sinking / cooling

<b>heating</b>	Automatic current reduction function not being utilized
	Reduce output current

## 9. Warranty

### Twelve Month Warranty

Leadshine Technology Co., Ltd. warrants its products against defects in materials and workmanship for a period of 12 months from shipment out of factory. During the warranty period, Leadshine will either, at its option, repair or replace products which proved to be defective.

### Exclusions

The above warranty does not extend to any product damaged by reasons of improper or inadequate handling by customer, improper or inadequate customer wiring, unauthorized modification or misuse, or operation beyond the electrical specifications of the product and/or operation beyond environmental specifications for the product.

### Obtaining Warranty Service

To obtain warranty service, please contact your seller to obtain a returned material authorization number (RMA) before returning product for service.

### Shipping Failed Products

If your product fail during the warranty period, please contact your seller for how and where to ship the failed product for warranty or repair services first, you can also e-mail customer service at [tech@leadshine.com](mailto:tech@leadshine.com) to obtain a returned material authorization number (RMA) before returning product for service. Please include a written description of the problem along with contact name and address.