

# X-100 Single Stage Rotary Vane Vacuum Pump

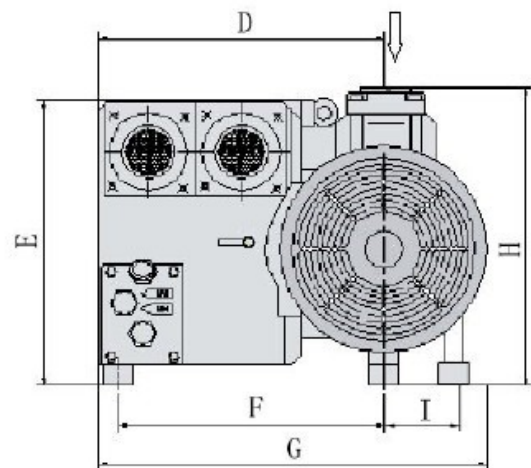

Item	Unit	X-100
Rated Speed	m <sup>3</sup> /h	100
Utmost Pressure	mbar	0.1-0.5
Noice	dB (A)	66
Work temperature	°C	85
Oil consumption	L	2
Vapor permitted pressure	mbar	40
Suction rate of vapour	kg/h	1.6
Whorl of inlet	inch	Rp1 1/4"
Whorl of outlet	inch	Rp1 1/4"
Motor rated power	kW	2.2
Motor rated rotating speed	rpm	1440
Total weight	kg	72
Vacuum pump size	cm	72*43*29.5

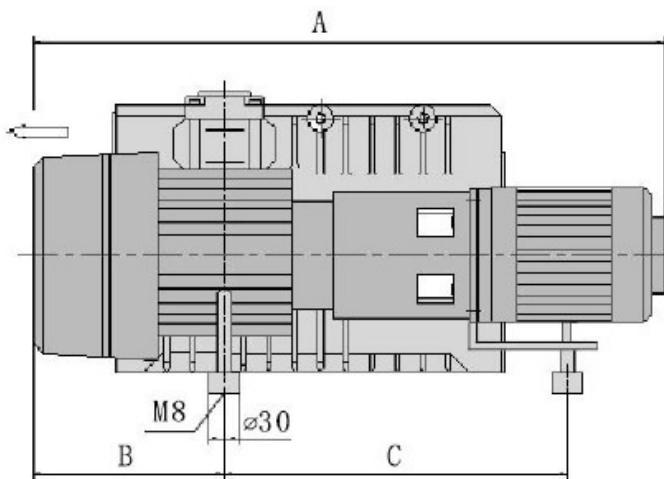

Dimension	A	B	C	D	E	F	G	H	I
X-100	720	180	295	295	285	278	430	295	-

## Vacuum Curve

标准排量  
Nominal  
displacement

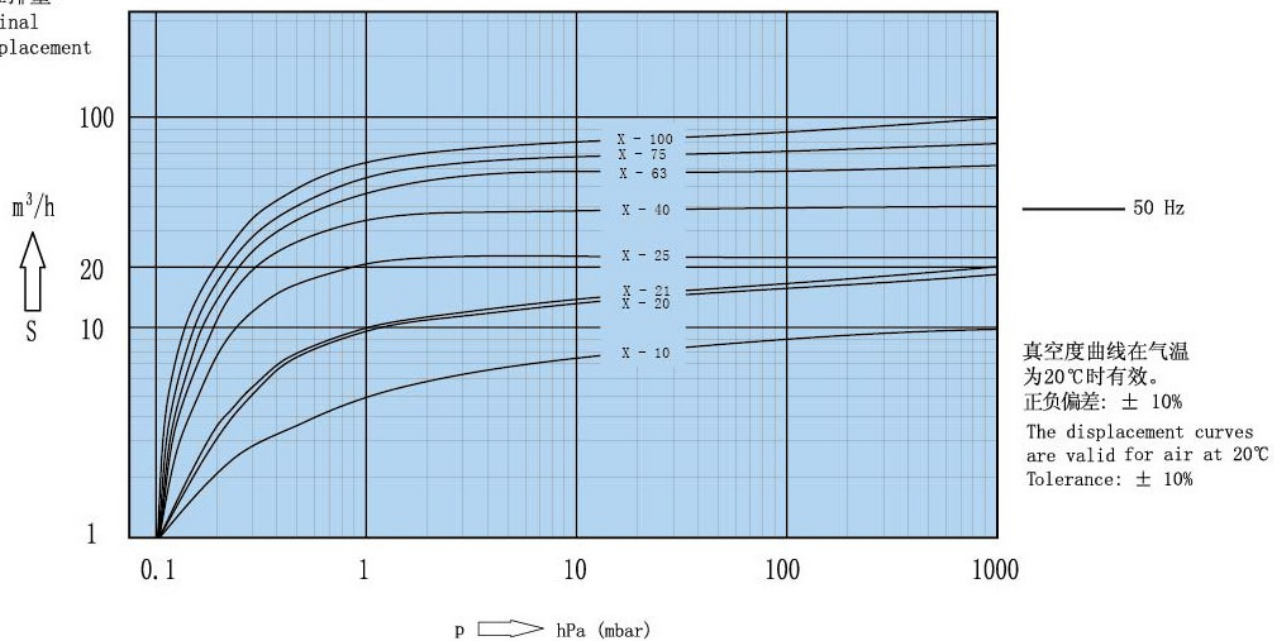

Product

link : <https://www.joysun-machinery.com/x-100-single-stage-rotary-vane-vacuum-pump.html>