

X-160 Single Stage Rotary Vane Vacuum Pump

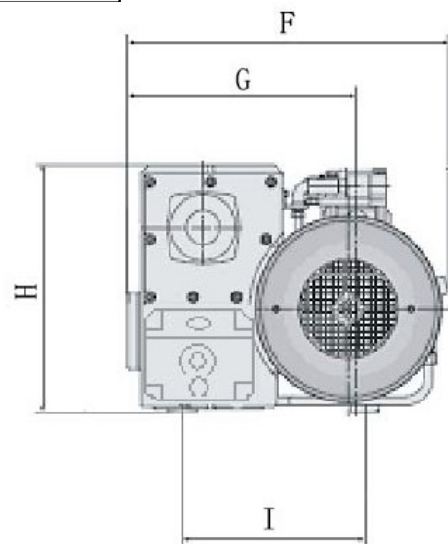

Item	Unit	X-160
Rated Speed	m ³ /h	160
Utmost Pressure	mbar	0.1-0.5
Noice	dB (A)	71
Work temperature	°C	65
Oil consumption	L	5
Vapor permitted pressure	mbar	40
Suction rate of vapour	kg/h	2.5
Whorl of inlet	inch	Rp2"
Whorl of outlet	inch	Rp2"
Motor rated power	kW	4
Motor rated rotating speed	rpm	1440
Total weight	kg	157
Vacuum pump size	cm	85.5*49.5*43.5

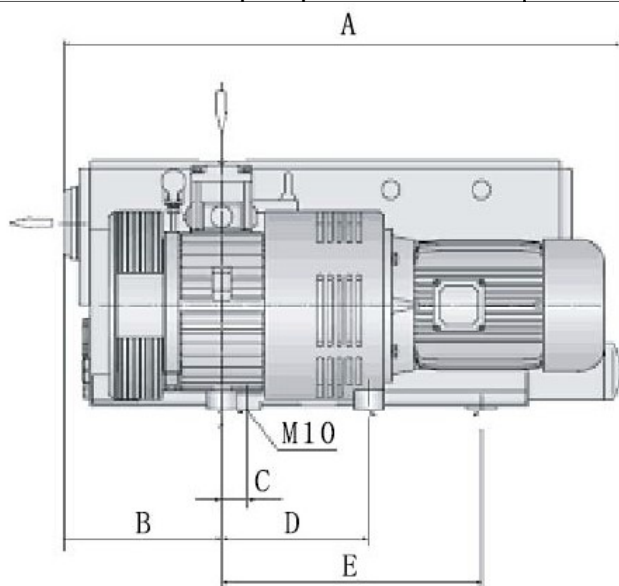

Dimension	A	B	C	D	E	F	G	H	I
X-160	855	225	40	240	430	495	345	435	310

Vacuum Curve

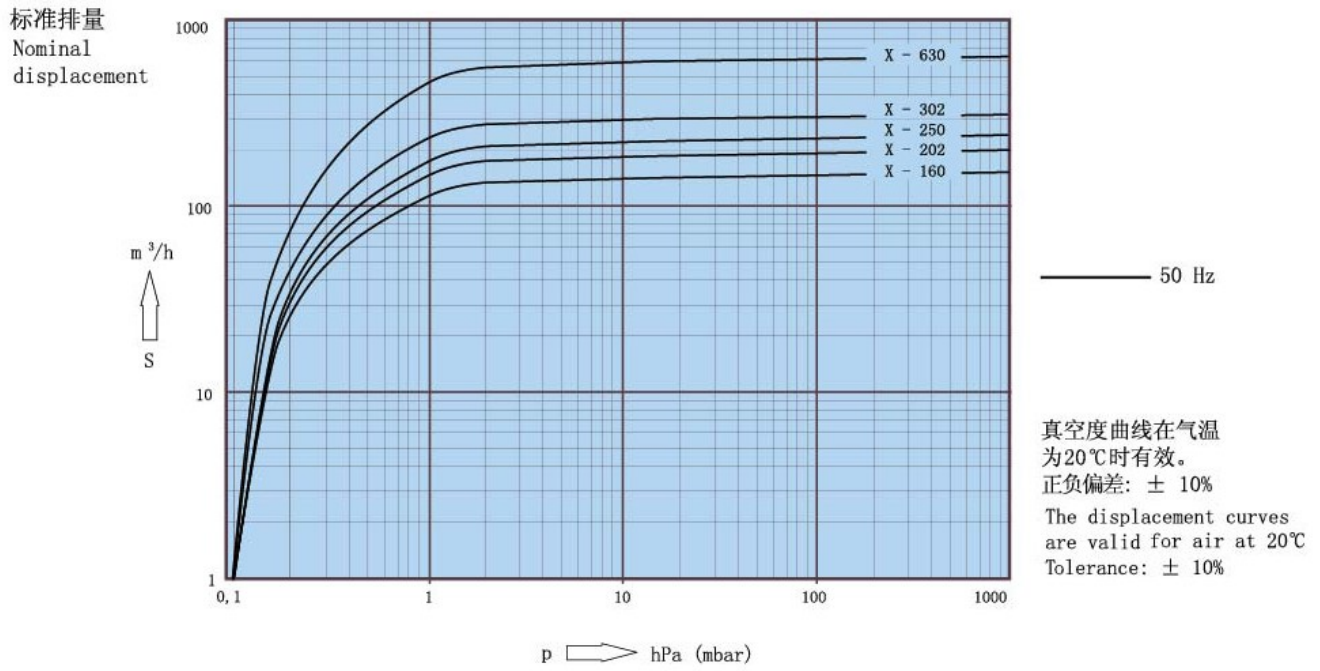

Product

link : <https://www.joysun-machinery.com/x-160-single-stage-rotary-vane-vacuum-pump.html>