

X-250 Single Stage Rotary Vane Vacuum Pump

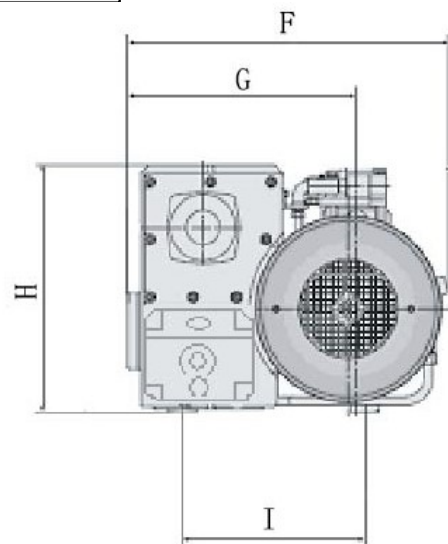

| Item | Unit | X-250 |
|----------------------------|-------------------|----------|
| Rated Speed | m ³ /h | 250 |
| Utmost Pressure | mbar | 0.1-0.5 |
| Noice | dB (A) | 73 |
| Work temperature | °C | 81 |
| Oil consumption | L | 8 |
| Vapor permitted pressure | mbar | 40 |
| Suction rate of vapour | kg/h | 4.5 |
| Whorl of inlet | inch | Rp2" |
| Whorl of outlet | inch | Rp2" |
| Motor rated power | kW | 5.5 |
| Motor rated rotating speed | rpm | 1440 |
| Total weight | kg | 195 |
| Vacuum pump size | cm | 98*56*44 |

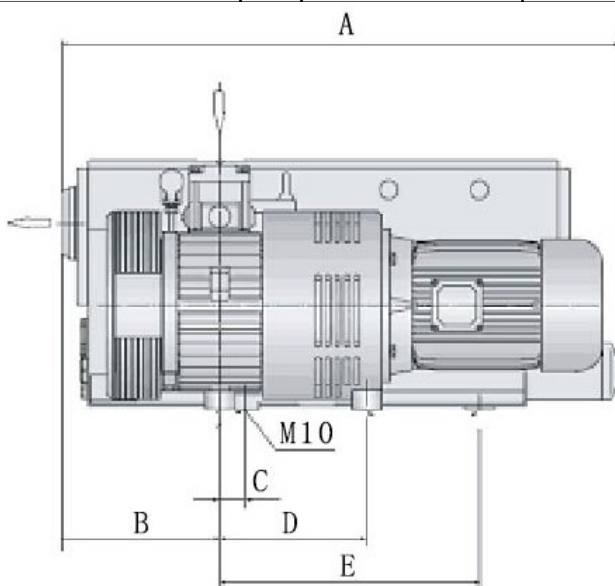

| Dimension | A | B | C | D | E | F | G | H | I |
|-----------|-----|-----|---|-----|-----|-----|-----|-----|-----|
| X-250 | 980 | 260 | - | 300 | 390 | 560 | 385 | 440 | 355 |

Vacuum Curve

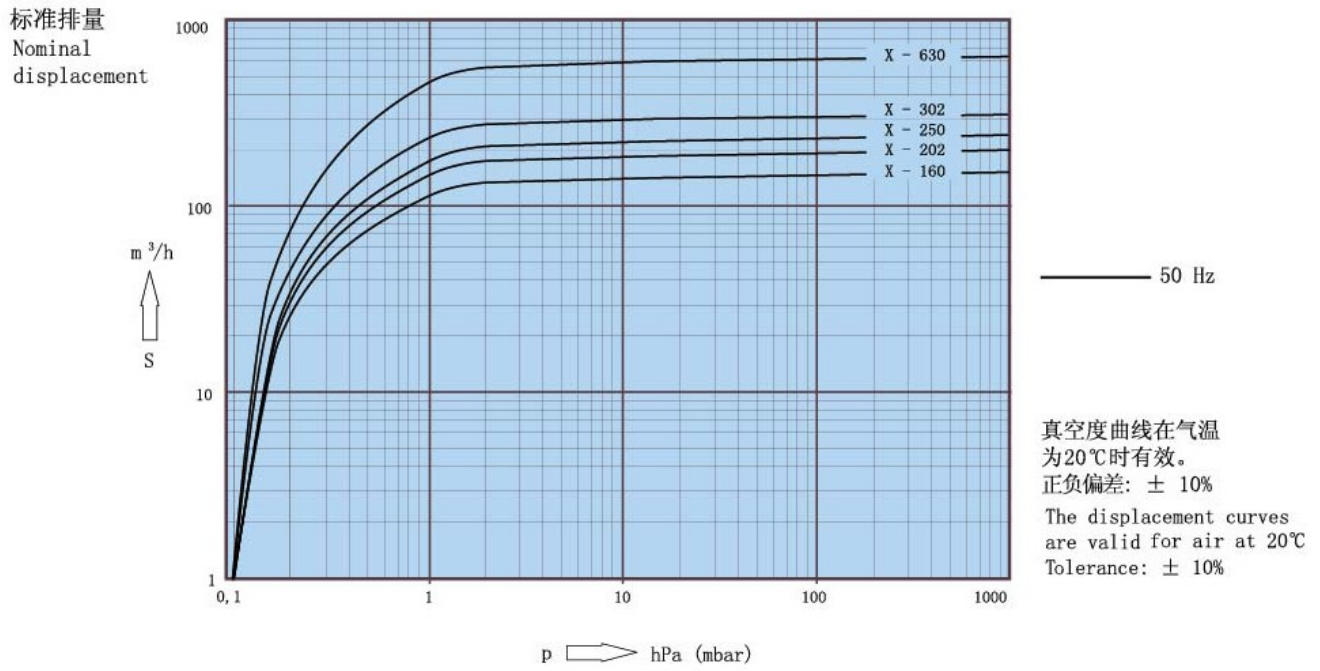

Product

link : <https://www.joysun-machinery.com/x-250-single-stage-rotary-vane-vacuum-pump.html>