

## Shear & Bending beam

# BSA/BSB/BSS/BS/HBS

CAS, we have great know-how in weighing and control technology, we design and build our own Load Cell that provides high-accuracy repeatability and correct measurement even in harsh environment.

CAS LOAD CELL

Ready-made product



# BSA | Shear Beam

## DESCRIPTION

The BSA is a low profile shear beam type Load Cell designed for platform scales, Tank scales and Hopper scales etc.

It is approved to OIML and NTEP

Via the use of threaded hole, easy intallation is possible.



## Specifications

Capacity	kgf	250, 500, 1K, 2K, 3K, 5K	
Rated Output	mV / V	3.0 ± 0.0075	
Zero Balance	mV / V	0.0 ± 0.03	
Accuracy Class	-	D3	C3
Non-Linearity	% R.O.	≤ 0.03	≤ 0.025
Hysteresis	% R.O.	≤ 0.03	≤ 0.025
Combined Error	% R.O.	≤ 0.03	≤ 0.025
Repeatability	% R.O.	≤ 0.01	≤ 0.01
Creep for 30min.	% R.O.	≤ 0.03	≤ 0.017
Return for 30min.	% R.O.	≤ 0.03	≤ 0.017
Resolution	-	≤ 1/3000	≤ 1/4000
Division	mV / V	0.001	0.00075
Temperature Effect on	- Zero Value	%/10°C	≤ 0.028
	- Output Value	%/10°C	≤ 0.015
Excitation	- Recommended	V	10
	- Maximum	V	15
Resistance	- Input	Ω	350 ± 3.5
	- Output	Ω	350 ± 3.5
	- Insulation	MΩ	> 2000
Compensated Temperature Range	°C	-10 to +40	
Operating Temperature Range	°C	-30 to +80	
Material & Plate	-	Nickel Plated Steel	
Cable Specification	-	Ø5.4 x 4P x 5M (Urethane)	
Safety Overload	% R.L.	150% R.L.	
Platform Size	mm	Without Limit	



## Features

- ▶ Max capacities of 250~5,000kg
- ▶ OIML C3 approval(OIML R60)
- ▶ NTEP Class III 5000d approval
- ▶ Low profile
- ▶ Nickel plated steel
- ▶ Threaded load hole

## Options

- ▶ TW bolt type accessory available
- ▶ TWE ball & safety guide bar type accessory available

## Dimension

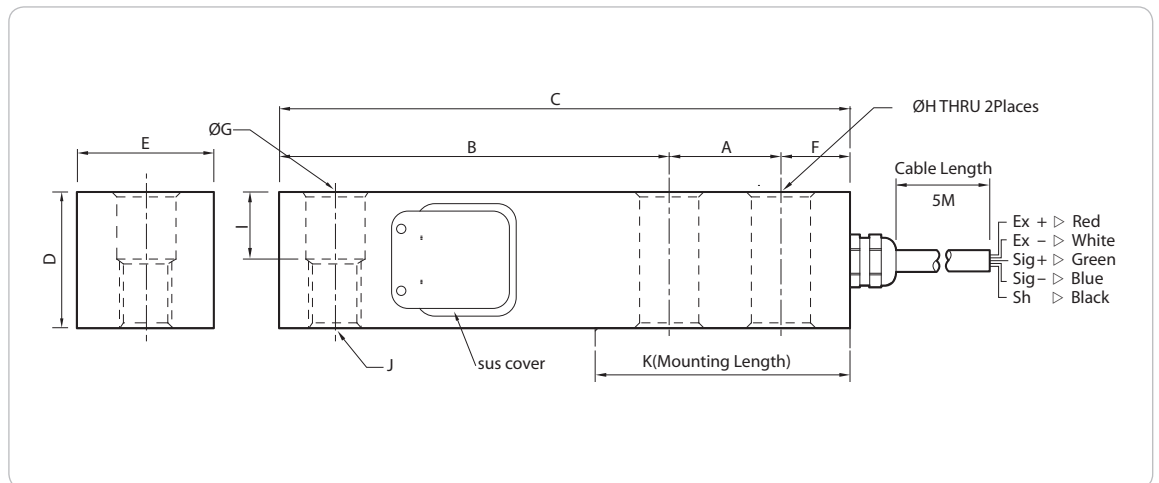

## Applications

- ▶ Platform scales
- ▶ Tank and hopper scales

Capa.	A	B	C	D	E	F	G	H	I	J	K
250kgf											
500kgf											
1tf	25.4	76.2	130	32	32	15.8	13.5	13.5	16	M12 x 1.75	52
2tf											
3tf	38.1	95.3	171.5	38	38	19	20	20	19	M18 x 1.5	76.2
5tf											

# BSB | Shear Beam

## DESCRIPTION

The BSB is a low profile shear beam type Load Cell designed for platform scales, Tank scales and Hopper scales etc.  
Its Nickel plating assures long term reliability.



## Specifications

Capacity	kgf	250, 500, 1K, 2K, 3K, 5K, 10K	
Rated Output	mV/V	3.0 ± 0.0075	
Zero Balance	mV/V	0.0 ± 0.03	
Accuracy Class	-	-	
Non-Linearity	% R.O.	≤ 0.03	
Hysteresis	% R.O.	≤ 0.03	
Combined Error	% R.O.	≤ 0.03	
Repeatability	% R.O.	≤ 0.01	
Creep for 30min.	% R.O.	≤ 0.03	
Return for 30min.	% R.O.	≤ 0.03	
Resolution	-	≤ 1/3000	
Division	mV/V	0.001	
Temperature Effect on	- Zero Value	%/10°C	≤ 0.028
	- Output Value	%/10°C	≤ 0.015
Excitation	- Recommended	V	10
	- Maximum	V	15
Resistance	- Input	Ω	350 ± 3.5
	- Output	Ω	350 ± 3.5
	- Insulation	MΩ	> 2000
Compensated Temperature Range	°C	-10 to +40	
Operating Temperature Range	°C	-30 to +80	
Material & Plate	-	Nickel Plated Steel	
Cable Specification	-	Ø5.4 x 4P x 5M (Urethane)	
Safety Overload	% R.L.	150%R.L.	
Platform Size	mm	4-Point Platform Type	

## Features

- ▶ Wide range of capacities from 250~10,000kg
- ▶ Low profile
- ▶ Nickel plated steel
- ▶ Threaded load hole

## Options

- ▶ TW bolt type accessory available  
(only for Low : 250 ~ 2K, High : 3K ~ 5K)
- ▶ TWE ball & safety guide bar type accessory available  
(only for Low : 250 ~ 2K, High : 3K ~ 5K)

## Dimension

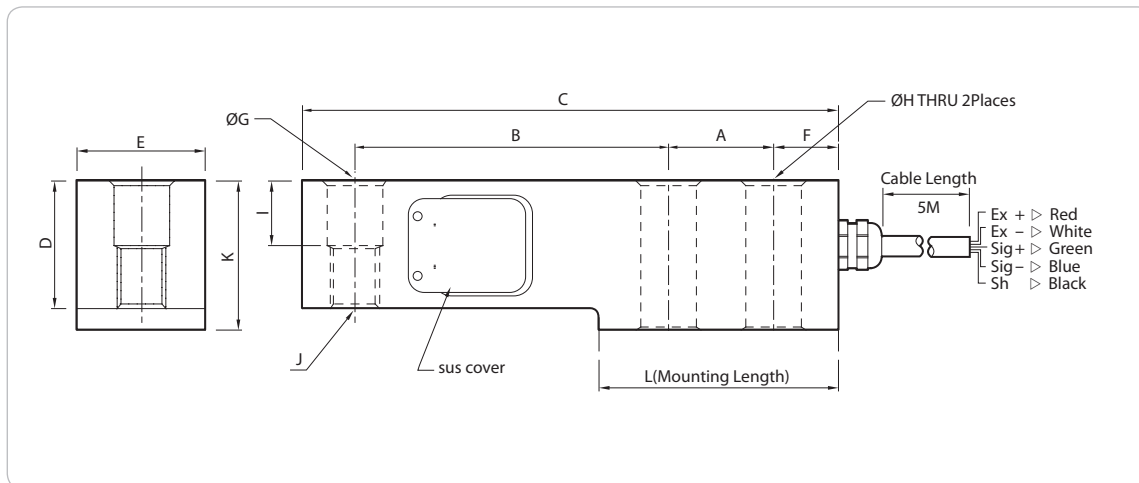

## Applications

- ▶ Platform scales
- ▶ Tank and hopper scales

Capa.	A	B	C	D	E	F	G	H	I	J	K	L
250kgf												
500kgf												
1tf	25.4	76.2	131	32	31.8	16.7	13.5	13.5	16	M12 x 1.75	38	57
2tf												
3tf												
5tf	38.1	95.3	172.5	38	38	20	20	20	19	M18 x 1.5	44.5	76
10tf	50.8	120.7	223.3	50.8	50.8	26.4	26.2	26.2	25.4	M24 x 2.0	57.2	101

# BSS | Shear Beam

## DESCRIPTION

The BSS is a low profile shear beam Load Cell. It is suitable for platform scales, pallet scales, tank scales and Hopper scales etc. The stainless steel design provides the best reliability in tank weighing applications. Approved to OIML and NTEP. It is available with Ex ia IIC T4 approval in hazardous areas.



## Specifications

Capacity		kgf	500, 1K, 2K, 3K, 5K	
Rated Output	mV/V		2.0 ± 0.005	
Zero Balance	mV/V		0.0 ± 0.02	
Accuracy Class	-		D3	C3
Non-Linearity	% R.O.		≤ 0.03	≤ 0.025
Hysteresis	% R.O.		≤ 0.03	≤ 0.025
Combined Error	% R.O.		≤ 0.03	≤ 0.025
Repeatability	% R.O.		≤ 0.01	≤ 0.01
Creep for 30min.	% R.O.		≤ 0.03	≤ 0.017
Return for 30min.	% R.O.		≤ 0.03	≤ 0.017
Resolution	-		≤ 1/3000	≤ 1/4000
Division	mV/V		0.0067	0.005
Temperature Effect on	- Zero Value	%/10°C	0.028	0.014
	- Output Value	%/10°C	0.014	0.011
Excitation	- Recommended	V	10	
	- Maximum	V	15	
Resistance	- Input	Ω	350 ± 3.5	
	- Output	Ω	350 ± 3.5	
	- Insulation	MΩ	> 2000	
Compensated Temperature Range	°C		-10 to +40	
Operating Temperature Range	°C		-30 to +80	
Material & Plate	-		Stainless Steel	
Cable Specification	-		Ø5.4 x 4P x 5M (Urethane)	
Safety Overload	% R.L.		150%R.L.	
Platform Size	mm		Without Limit	



## Features

- ▶ Max capacities of 500~5,000kg
- ▶ OIML C3 approval (OIML R60)
- ▶ NTEP Class III 5000d approval
- ▶ Low profile
- ▶ Stainless steel
- ▶ Threaded load hole

## Options

- ▶ TW bolt type accessory available
- ▶ TWE ball & safety guide bar type accessory available
- ▶ Ex ia IIC T4 approval type

## Dimension

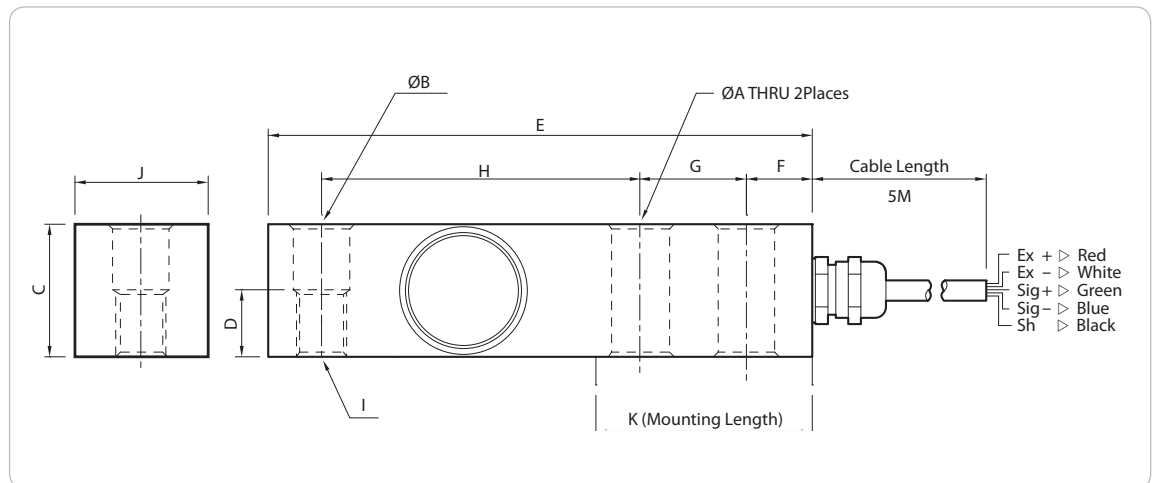

## Applications

- ▶ Platform scales
- ▶ Tank and hopper scales

Capa.	A	B	C	D	E	F	G	H	I	J	K
500kgf											
1tf	13.5	13.5	31.7	15.8	130	15.8	25.4	76.2	M12 x 1.75	31.7	52
2tf											
3tf	20	20	38.1	19.1	171.5	19	38.1	95.3	M18 x 1.5	38.1	76.2
5tf											

# BS | Shear Beam

## DESCRIPTION

The BS is a low profile shear beam Load Cell. It is nickel plated steel and designed for platform scales, Tank scales and Hopper scales etc.



## Specifications

Capacity		kgf	250, 500	1K, 2K, 5K, 10K
Rated Output		mV / V	1.5 ± 0.0037	2.0 ± 0.005
Zero Balance		mV / V	0.0 ± 0.015	0.0 ± 0.02
Accuracy Class		-	-	
Non-Linearity		% R.O.	≤ 0.03	
Hysteresis		% R.O.	≤ 0.03	
Combined Error		% R.O.	≤ 0.03	
Repeatability		% R.O.	≤ 0.01	
Creep for 30min.		% R.O.	≤ 0.03	
Return for 30min.		% R.O.	≤ 0.03	
Resolution		-	≤ 1/3000	
Division		mV / V	0.0005	0.00067
Temperature Effect on	- Zero Value	%/10°C	≤ 0.028	
	- Output Value	%/10°C	≤ 0.015	
Excitation	- Recommended	V	10	
	- Maximum	V	15	
Resistance	- Input	Ω	350 ± 20	
	- Output	Ω	350 ± 5	
	- Insulation	MΩ	> 2000	
Compensated Temperature Range		°C	-10 to +40	
Operating Temperature Range		°C	-20 to +80	
Material & Plate		-	Nickel Plated Steel	
Cable Specification		-	Ø5.4 x 4P x 3M (Urethane)	
Safety Overload		% R.L.	150	
Platform Size		mm	Without Limit	

## Features

- ▶ Max capacities of 250~10,000kg
- ▶ Low profile
- ▶ Nickel plated steel

## Options

- ▶ Ball type accessory available

## Dimension

▶250kgf~5tf

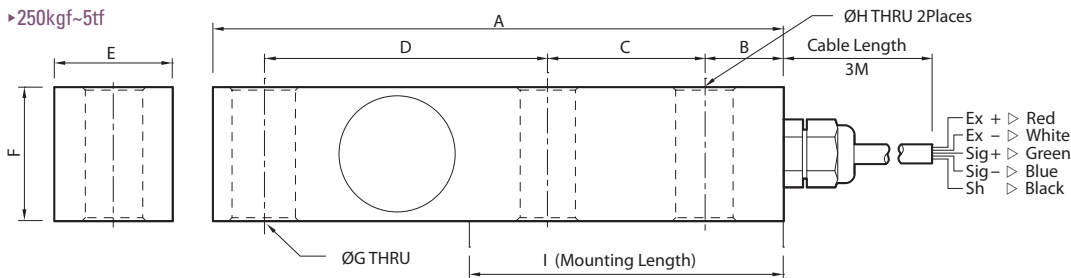

Capa.	A	B	C	D	E	F	G	H	I
250kgf ~ 2tf	145.0	20.0	40.0	72.0	34.0	30.0	16.0	14.5	80.0
5tf	205.0	25.0	55.0	105.0	48.0	38.0	20.5	20.5	105.0

▶10tf

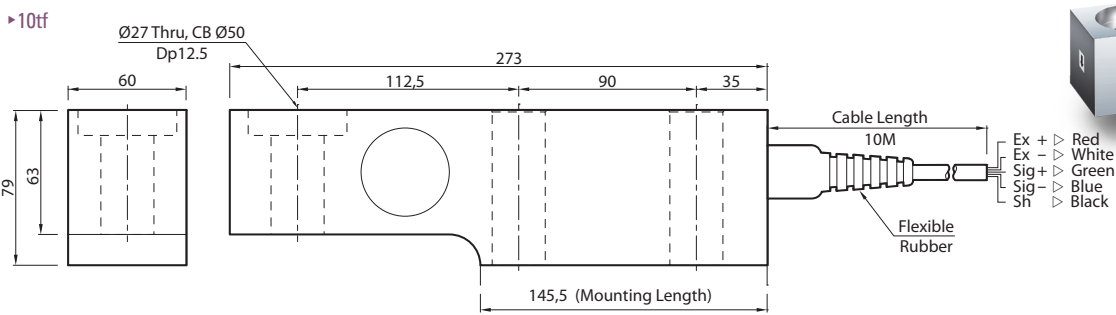

## Applications

- ▶ Platform scales
- ▶ Tank and hopper scales

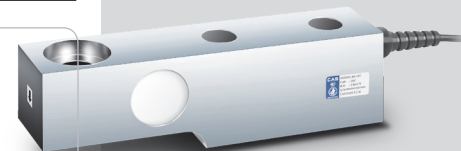

▶BS(10tf)

# HBS | Bending Beam

## DESCRIPTION

The HBS is a fully weld-sealed stainless steel bending type Load Cell. It is designed for platform scales, belt scales, tank scales and hopper scales etc. Approved to OIML. It is available with Ex ia IIC T4 approval in hazardous areas. (only for capacities of 10~500kg)



## Specifications

Capacity		kgf	10, 20, 50, 100, 200, 500, 1K, 2K	
Rated Output		mV/V	2.0 ± 0.005	
Zero Balance		mV/V	0.0 ± 0.02	
Accuracy Class		-	D3	C3
Non-Linearity		% R.O.	≤ 0.03	≤ 0.02
Hysteresis		% R.O.	≤ 0.03	≤ 0.02
Combined Error		% R.O.	≤ 0.03	≤ 0.02
Repeatability		% R.O.	≤ 0.01	≤ 0.01
Creep for 30min.		% R.O.	≤ 0.03	≤ 0.017
Return for 30min.		% R.O.	≤ 0.03	≤ 0.017
Resolution		-	≤ 1/3000	≤ 1/5000
Division		mV/V	0.00067	0.0002
Temperature Effect on	- Zero Value	%/10°C	≤ 0.028	≤ 0.014
	- Output Value	%/10°C	≤ 0.015	≤ 0.011
Excitation	- Recommended	V	10	
	- Maximum	V	15	
Resistance	- Input	Ω	400 ± 20	
	- Output	Ω	350 ± 3.5	
	- Insulation	MΩ	> 2000	
Compensated Temperature Range		°C	-10 to +40	
Operating Temperature Range		°C	-30 to +80	
Material & Plate		-	Stainless Steel, Buffing	
Cable Specification		-	Ø5.4 x 4P x 3M (Urethane)	
Safety Overload		% R.L.	150%R.L.	
Platform Size		mm	Without Limit	



## Features

- ▶ Max capacities of 10~2,000kg
- ▶ OIML C3 approval (OIML R60)
- ▶ Fully welded, Stainless steel
- ▶ Braided shield 4 wire cable with urethane-jacket

## Options

- ▶ Ball type accessory available
- ▶ Ex ia IIC T4 approval type (only for capacities of 10~500kg)

## Dimension

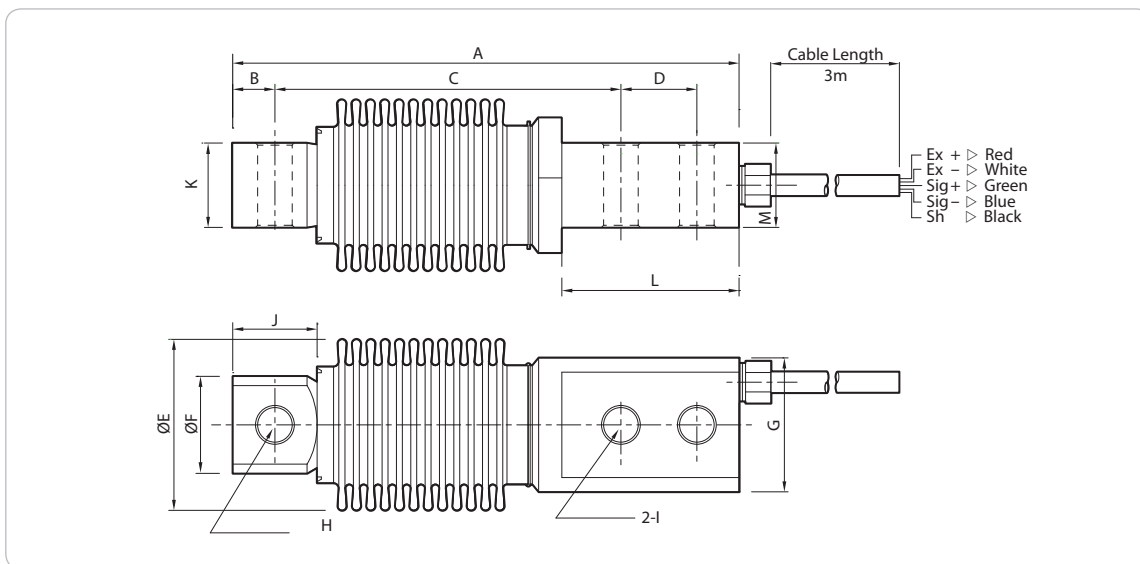

## Applications

- ▶ Platform scales
- ▶ Belt scales
- ▶ Tank and hopper scales

Capa.	A	B	C	D	E	F	G	H	I	J	K	L	M
10kgf~500kgf	120	10	82	18	Ø40	Ø23	31.75	Ø8.2	Ø8.2	20	20	42	20
1tf~2tf	210	20	125	50	Ø66	Ø40	52	Ø16	Ø18	40	30	90	40

Dimensions(BSA, BSB(without spacer), BSS-TW)

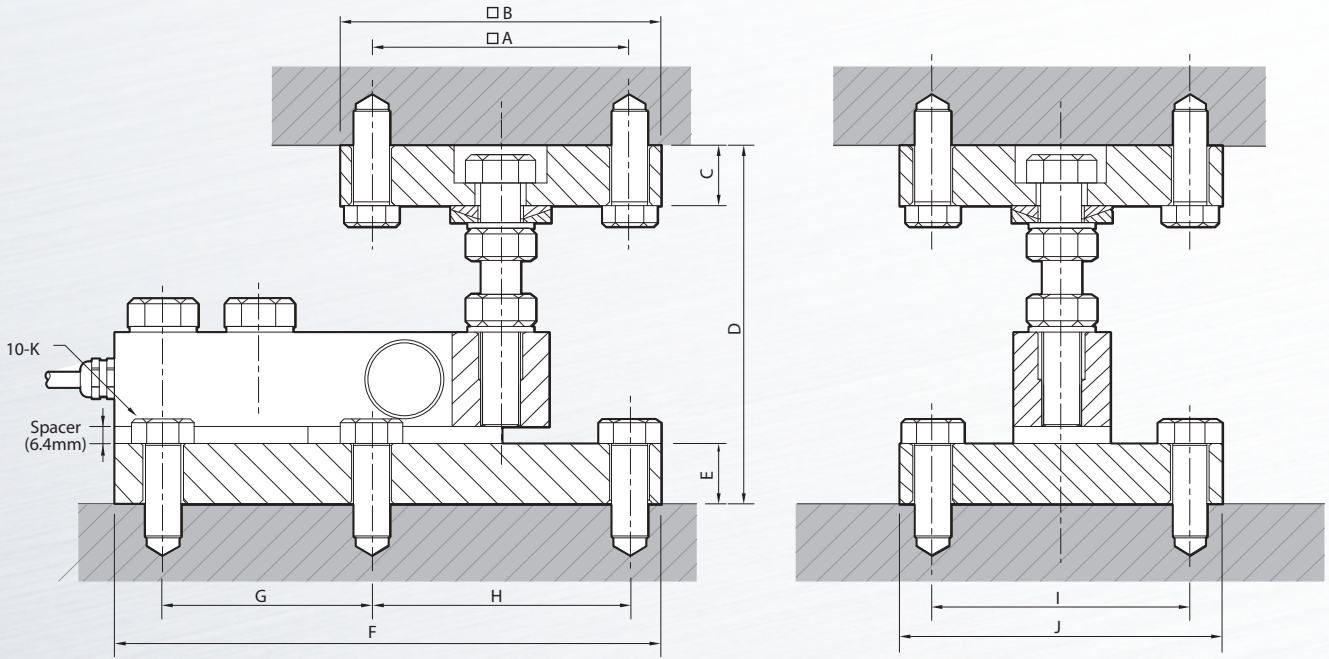

Capa.	A	B	C	D	E	F	G	H	I	J	K
500kgf											
1tf	101.6	12.7	17.8	115.9~123.9	17.8	180.9	52.3	101.6	101.6	127	M16
2tf											
3tf	101.6	127	23.9	136~144	23.9	215.9	82.5	101.6	101.6	127	M16
5tf											

Dimensions(BSA, BSB(without spacer), BSS-TWE)

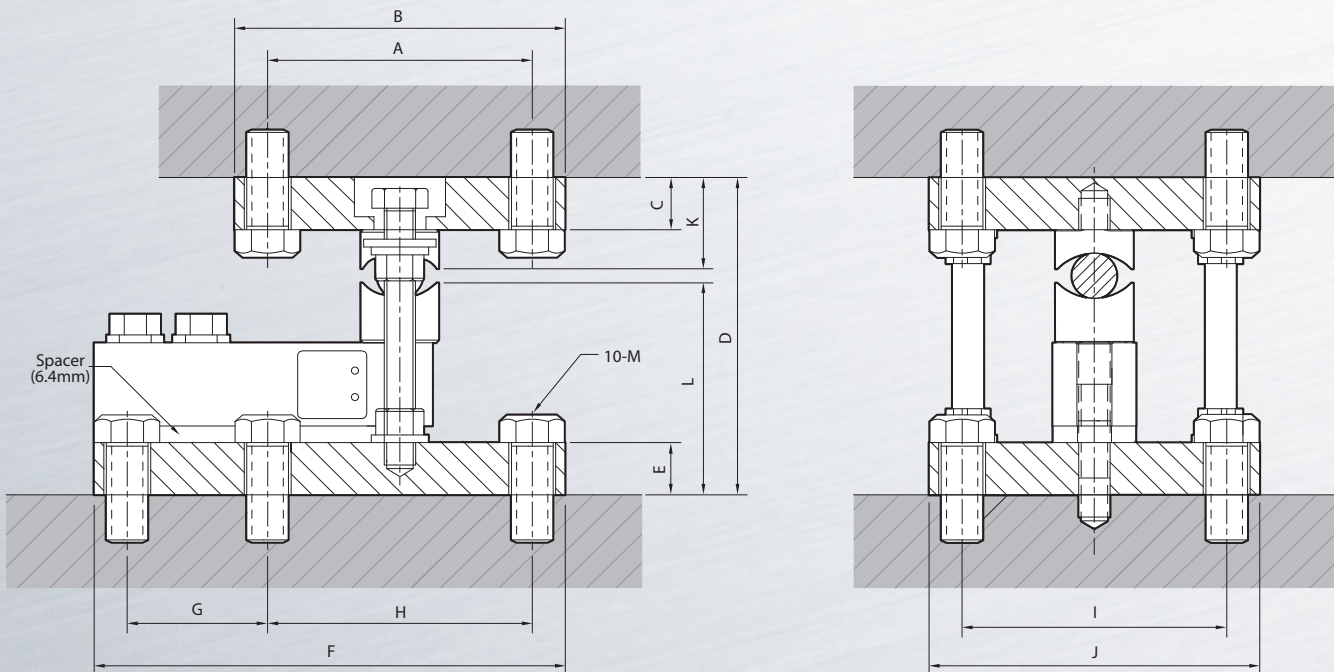

Capa.	A	B	C	D	E	F	G	H	I	J	K	L	M
500kgf													
1tf	101.6	127	20	121.8	20	180.9	53.9	101.6	101.6	127	35	81.4	M16
2tf													
3tf	101.6	127	26	154.6	24	215.9	82.5	101.6	101.6	127	45	94.6	M16
5tf													

### Dimensions(BS-250kgf~5tf)

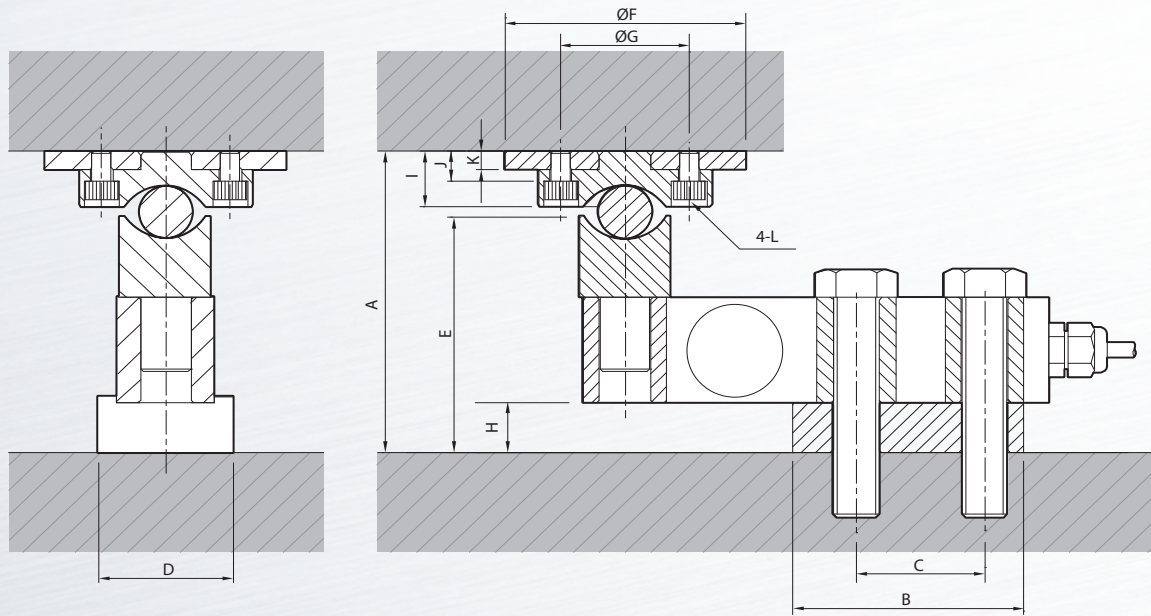

Capa.	A	B	C	D	E	F	G	H	I	J	K	L
250kgf	97.4	72.0	40.0	42.0	76.0	75.0	40.0	16.0	18.0	10.0	6.0	M6 x 1.0
500kgf												
1tf												
2tf	134.0	100.0	55.0	48.0	84.0	100.0	50.0	16.0	40.0	25.0	15.0	M10 x 1.5
5tf												

### Dimensions(BS-10tf)

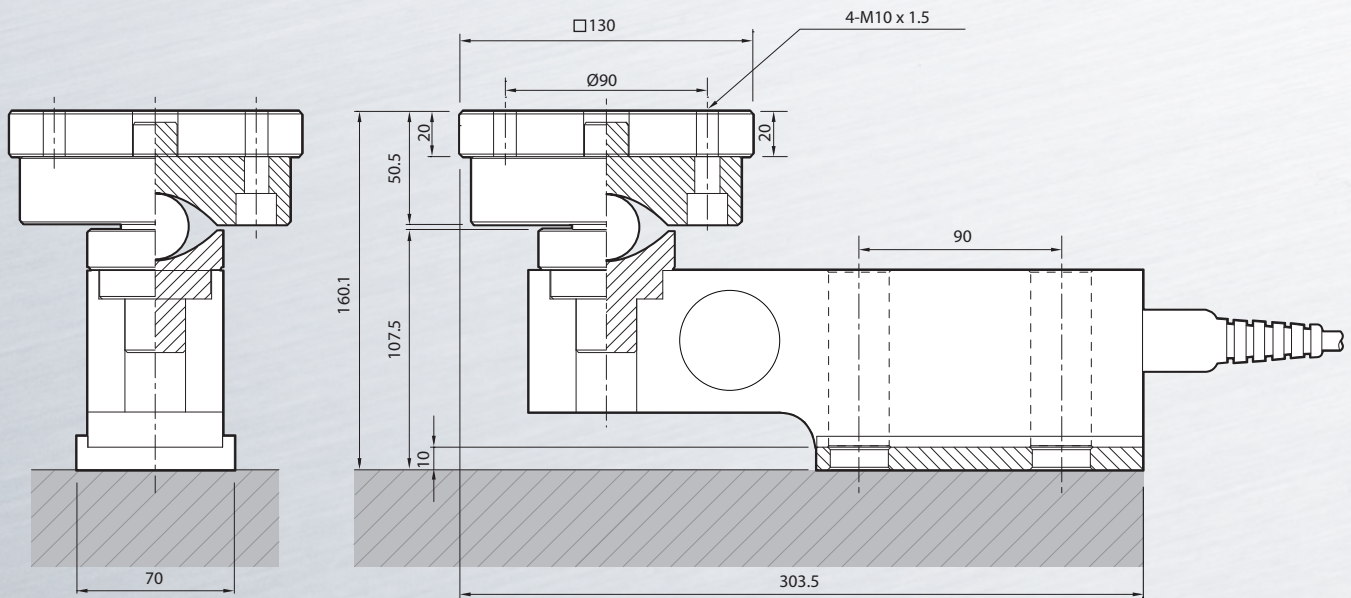



## Dimensions(HBS-10~500kgf)

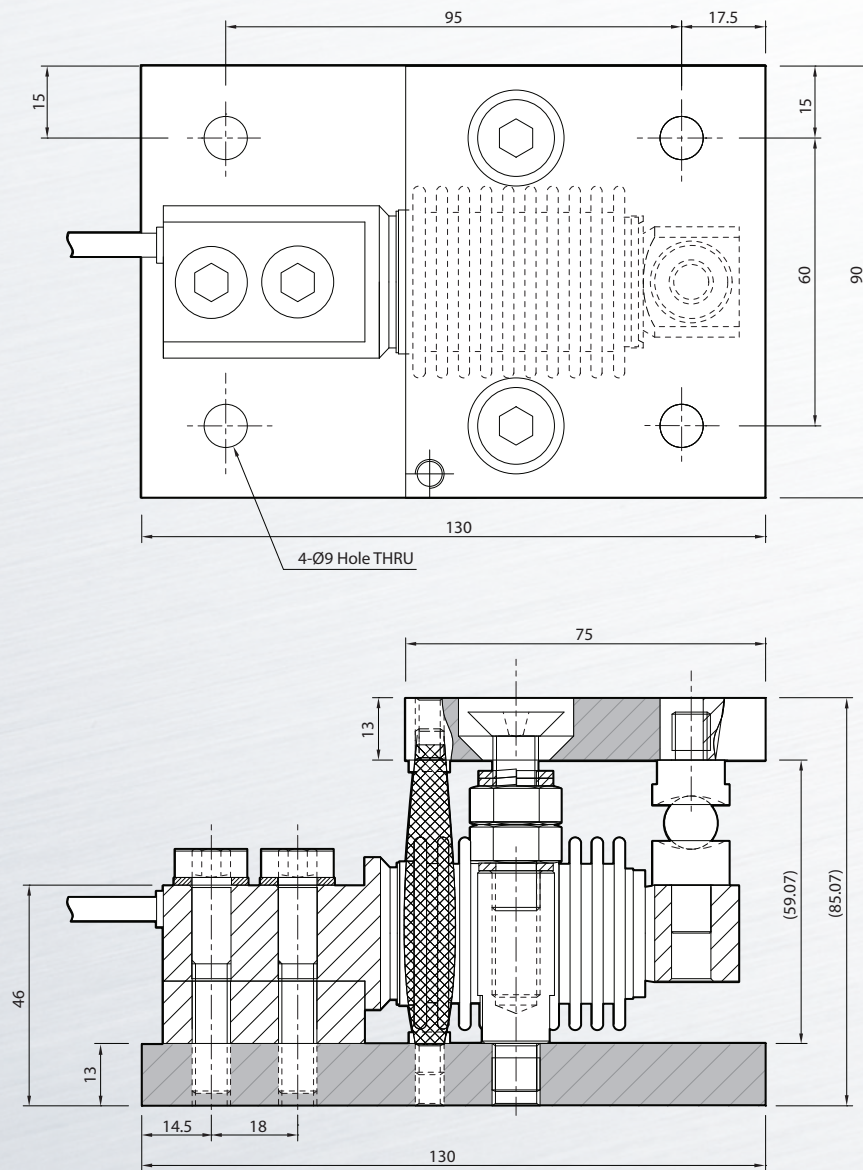

### BSA/BSB(without spacer)/BSS

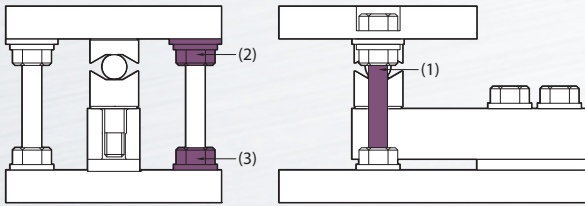

1. Tighten Hex (1) Hex bolt to Mounting plate powerfully.
2. Tighten (2) & (3) hex nut to both ends to close.
3. Tighten Hex bolt and nut in the opposite side like No.1 and 2.
4. Install Load Cell assembled with Ball cup.

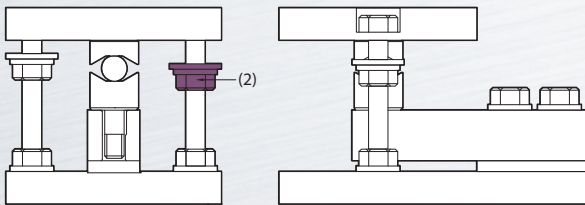

1. Loose slowly (2) Hex nut .
2. Loose Hex nut in the opposite side.
3. Loose Hex nut until it doesn't affect the weighing when the weight is loaded.
4. Use Hex nut like (2) to adjust height when replacing.

### HBS

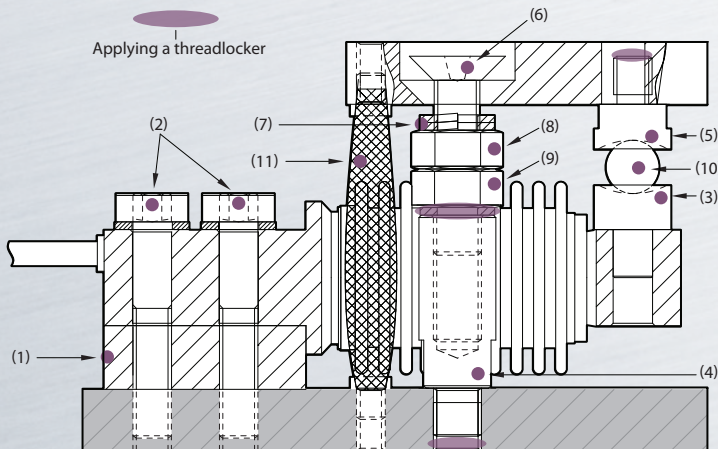

NO.	
(1)	Spacer
(2)	Hex socket head cap screw & washer
(3)	Lower ball cup
(4)	Supporter
(5)	Upper ball cup
(6)	Hex socket flat head cap screw
(7)	Washer
(8)	Hex nut
(9)	Hex nut(Thin)
(10)	Steel ball
(11)	By-pass strap

1. Assemble (1) Spacer and Base plate, and then Load Cell with (2) Hex socket head cap screw & washer.
2. Assemble (3) Lower ball cup and Load Cell.
3. After assembling (4) Supporter and Base plate, apply a threadlocker.
4. After assembling (5) Upper ball cup and Upper plate, apply a threadlocker
5. Assemble (6) Hex socket flat head cap screw(M10) and Upper plate, and then (7) Washer(M10) and (8)(9) Hex nut(M10).
6. Assemble (6) Hex socket flat head cap screw(M10) of Upper plate and (4) Supporter of Base plate.(Depth : approx. 10mm)
7. Put (10) Ball into between (3) and (5) assembled Ball cup.
8. Tighten (9) Hex nut toward (4) Supporter to be fixed fully and then apply a threadlocker.
9. Connect (11) By-pass Strap between Upper plate and Base plate.
10. Loose down and adjust (8) Hex nut as suitably as the weight can be transmitted.

## HOPPER SCALE

Overall view

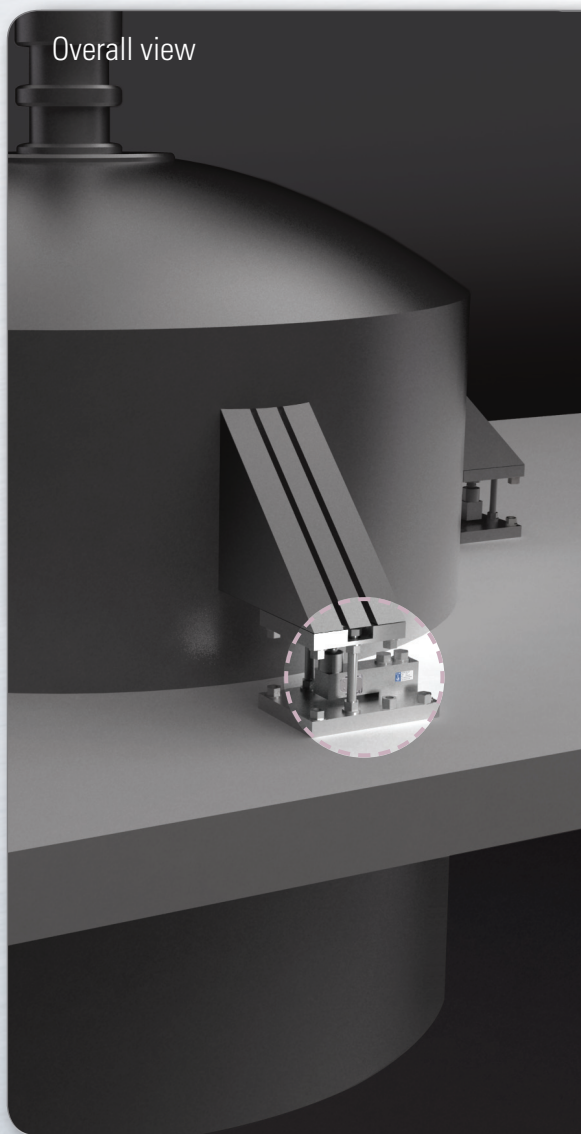

Detail view

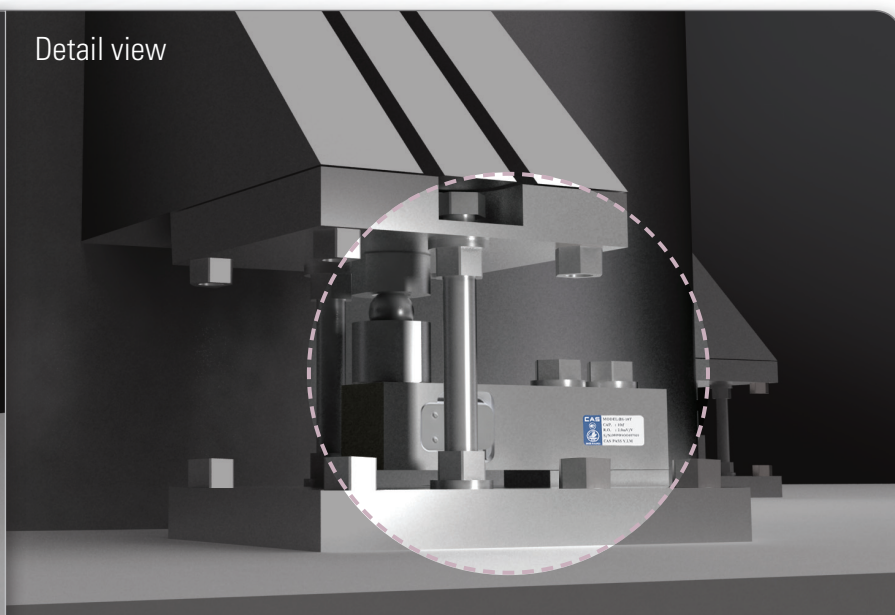

Detail drawing

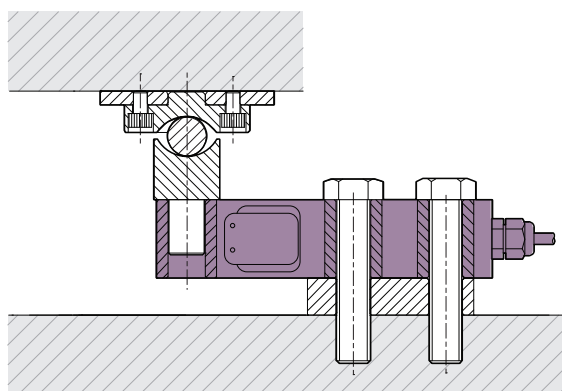

### Process weighing-Hoppers, tanks, silos

CAS shear & bending beam type Load Cell assembled with Load Cell accessory offers high- accuracy, repeatability and correct measurement in the process environment.



Hopper system



## PLATFORM SCALE

Overall view

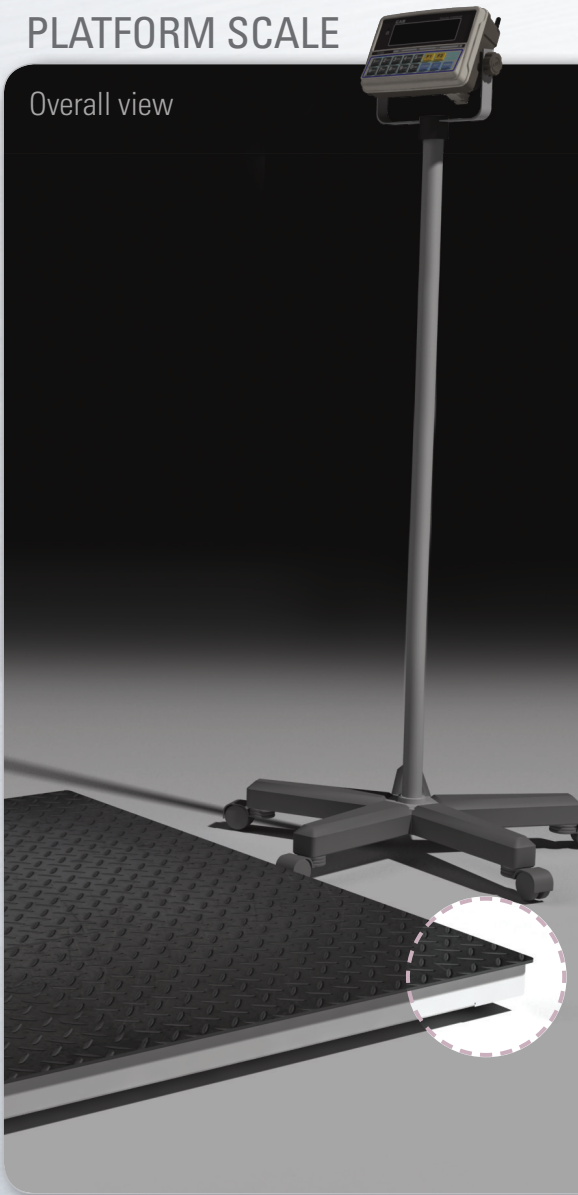

Detail view

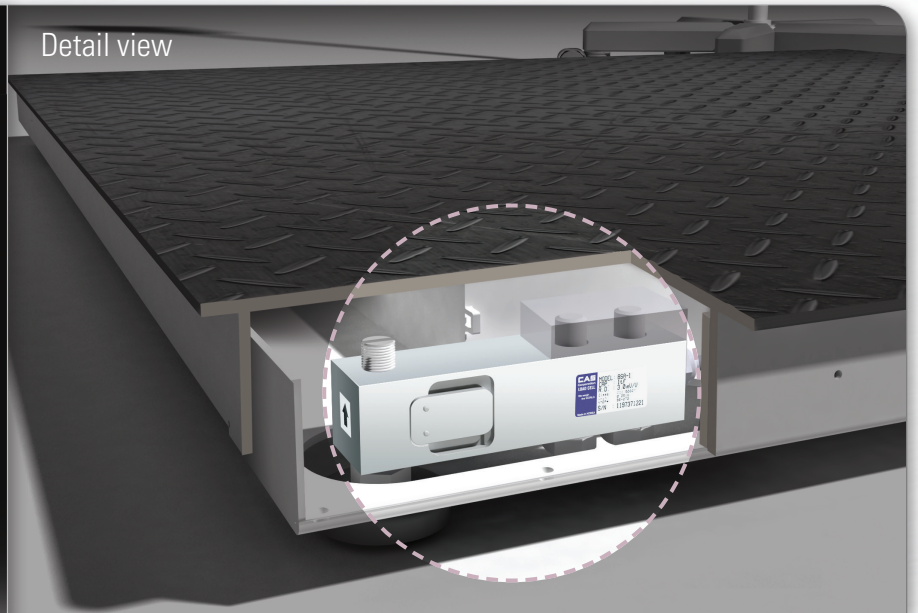

Detail drawing

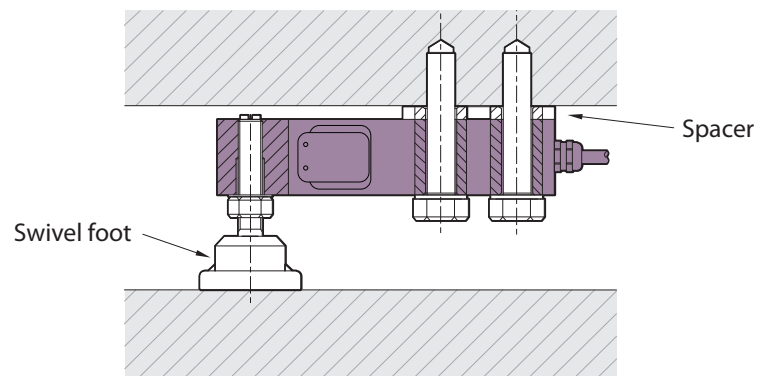

### Static loading

CAS shear & bending beam type Load Cell is ideal for general purpose weighing in static loading application such as CAS platform scale HFS and HPS.



Warehouse & Distribution center



## Asia

Republic of Korea

### Headquarter

#19 GANAP-RI GWANGJUK-MYOUN, YANGJU-SI GYEONGGI-DO, Rep. of KOREA  
Tel : 82 - 31 - 820 -1100  
Fax : 82 -31 - 840 - 6489

### Seoul Office

CAS BLDG., #440-1, SUNGNAE-DONG, GANGDONG-GU, SEOUL, KOREA  
TEL : 82-2-2225-3500  
FAX : 82-2-475-4668

China

### CAS\_CHINA

1501 HAO, MAIXIN-LU, XINQIAO-ZHEN, SONGJIANG-QU, SHANGHA, CHINA  
Tel : 86-21-5768-0558  
Fax : 86-21-5768-0560

India

### CAS\_INDIA

568, UDYOG VIHAR, PHASE-V, GURGAON - 122016 HARYANA, INDIA  
Tel : 91-124-234-2621/3/4  
Fax : 91-124-234-2626

Vietnam

### CAS\_VIETNAM

90/8 PHAN VAN HON ST. TAN THOI NHAT WARD DIST. 12 HCMC, VIETNAM  
Tel : 84-8-37192266~7  
Fax : 84-8-37190919

Bangladesh

### CAS\_BANGLADESH

44/F16, TEJTURI BAZAR CHALK WEST RAJABAZAR, TEJGAON, DHAKA 1215, BANGLADESH  
Tel : 88-2-911-2020, 88-2-814-1351  
Fax : 88-2-911-2020

Pakistan

### CAS\_PAKISTAN

A-17, #365 J-III BLOCK M.A JOHAR TOWN LAHORE, PAKISTAN  
Tel : 92-423-595-7336  
Fax : 92-423-595-7336

## America

United States

### CAS\_USA

99 MURRAY HILL PARKWAY EAST RUTHERFORD, NJ 07073  
Tel : 1-201-933-9002  
Fax : 1-201-933-9025

Nicaragua

### CAS\_NICARAGUA

CALLE PRINCIPAL ALTAMIRA, DEL HOSPITAL CENTRAL 2C AL NORTE (LAGO), MANAGUA, NICARAGUA  
Tel : 505-2277-2616

## Europe

Russia

### CAS\_RUSSIA

Russia 125080, Moscow, Volokolamskoe shosse building 1, 5th floor, office 506  
Tel : 7-499-271-6627  
Fax : 7-499-271-6628

Turkey

### CAS\_TURKEY

YUKARI DUDULLU BOSTANCI CAD MEVDUDI SOK NO:34 UMRANIYE / ISTANBUL TURKEY  
Tel : 90-216-540-8120  
Fax : 90-216-540-8128

Deutschland

### CAS\_DEUTSCHLAND

AG BROITZEMER STRASSE 202 D-38118 BRAUNSCHEWIG  
Tel : 49-531-12979-0  
Fax : 49-531-12979-29

Poland

### CAS\_POLAND

SP. ZOO. CHROSCICKIEGO 93/105 02-414 WARSAW, POLAND  
Tel : 48-22-5719-470  
Fax : 48-22-5719-471

France

### CAS\_FRANCE

PARC D'ACTIVITÉS DU VERT GALANT 6 RUE DES OZIERES BP 37039 SAINT OUEN L'AUMÔNE F95021 CERGY PONTOISE CEDEX  
Tel : 33-1-34-02-15-04  
Fax : 33-1-34-02-15-06